



# ***ST-765SS-DCL Free Chlorine + Sulfite***

*Multi-Parameter Sensor for Chemical Dechlorination  
in Cooling & Process Water*



**Pyxis Lab® Inc.**

1729 Majestic Dr. (Suite 5)

Lafayette, CO 80026

[www.pyxis-lab.com](http://www.pyxis-lab.com)

V1.07

**USER MANUAL**

## Table of Contents

<b>1. Introducing the Pyxis ST-765SS-DCL Sensor .....</b>	<b>4</b>
1.1 Specifications.....	5
1.2 Unpacking the ST-765SS-DCL.....	6
1.3 Standard Accessories.....	6
1.4 Optional Accessories .....	6
<b>2. Dimension.....</b>	<b>7</b>
<b>3. ST-007 Installation &amp; Operation For CLEAN WATER ONLY .....</b>	<b>9</b>
<b>4. FR-300-PLUS Installation &amp; Operation For INDUSTRIAL WATER ONLY.....</b>	<b>10</b>
<b>5. Wiring of ST-765SS-DCL Sensor &amp; FR-300-PLUS Flow Reservoir .....</b>	<b>14</b>
<b>6. Calibration and Diagnosis .....</b>	<b>15</b>
6.1 Calibration and Diagnosis by uPyxis Mobile App.....	15
6.1.2 Free Chlorine Calibration w/uPyxis MOBILE.....	16
6.1.2 Sulfite Calibration w/uPyxis MOBILE .....	18
6.1.3 pH Calibration w/uPyxis MOBILE.....	20
6.1.4 4-20mA Span w/uPyxis MOBILE.....	21
6.1.5 Diagnosis w/uPyxis MOBILE .....	22
6.2 Calibration and Diagnosis by uPyxis Desktop App.....	23
6.2.1 Free Chlorine Calibration w/uPyxis DESKTOP .....	26
6.2.2 Sulfite Calibration w/uPyxis DESKTOP .....	27
6.2.3 pH Calibration w/uPyxis DESKTOP.....	28
6.2.4 4-20mA Span w/uPyxis DESKTOP .....	30
6.2.5 Diagnosis w/uPyxis DESKTOP .....	31
6.3 Calibration through the Controller .....	31
<b>7. Modbus RTU .....</b>	<b>31</b>
<b>8. Sensor Cleaning and Maintenance.....</b>	<b>32</b>
8.1 Other Common Troubleshooting Issues.....	32
<b>9. Replacing pH and Oxidizer Electrode Head.....</b>	<b>33</b>
<b>10. Contact Us.....</b>	<b>34</b>

## **Warranty Information**

### **Confidentiality**

The information contained in this manual may be confidential and proprietary and is the property of Pyxis Lab, Inc. Information disclosed herein shall not be used to manufacture, construct, or otherwise reproduce the goods described. Information disclosed herein shall not be disclosed to others or made public in any manner without the express written consent of Pyxis Lab, Inc.

### **Standard Limited Warranty**

Pyxis Lab warrants its products for defects in materials and workmanship. Pyxis Lab will, at its option, repair or replace instrument components that prove to be defective with new or remanufactured components (i.e., equivalent to new). The warranty set forth is exclusive and no other warranty, whether written or oral, is expressed or implied.

### **Warranty Term**

The Pyxis warranty term for the ST-765SS Series sensor body is thirteen (13) months from original shipment from Pyxis. The Pyxis warranty term for the EH-765 (electrode reference head) installed on the ST-765SS Series sensor body is six (6) months from original shipment from Pyxis. In no event shall the standard limited warranty coverage extend beyond this timeline from original shipment date.

### **Warranty Service**

Damaged or dysfunctional instruments may be returned to Pyxis for repair or replacement. In some instances, replacement instruments may be available for short duration loan or lease.

Pyxis warrants that any labor services provided shall conform to the reasonable standards of technical competency and performance effective at the time of delivery. All service interventions are to be reviewed and authorized as correct and complete at the completion of the service by a customer representative, or designate. Pyxis warrants these services for 30 days after the authorization and will correct any qualifying deficiency in labor provided that the labor service deficiency is exactly related to the originating event. No other remedy, other than the provision of labor services, may be applicable.

Repair components (parts and materials), but not consumables, provided during a repair, or purchased individually, are warranted for 90 days ex-works for materials and workmanship. In no event will the incorporation of a warranted repair component into an instrument extend the whole instrument's warranty beyond its original term.

### **Warranty Shipping**

A Repair Material Authorization (RMA) Number must be obtained from Pyxis Technical Support before any product can be returned to the factory. Pyxis will pay freight charges to ship replacement or repaired products to the customer. The customer shall pay freight charges for returning products to Pyxis. Any product returned to the factory without an RA number will be returned to the customer. To receive an RMA you can generate a request on our website at [Request Return or Repair - Pyxis Lab, Inc. \(pyxis-lab.com\)](https://www.pyxis-lab.com/Request-Return-or-Repair)

### **Pyxis Technical Support**

Contact Pyxis Technical Support at +1 (866) 203-8397, ext. 2 [service@pyxis-lab.com](mailto:service@pyxis-lab.com)

## 1. Introducing the Pyxis ST-765SS-DCL Sensor

### Description

Pyxis ST-765SS-DCL is a four-parameter composite sensor used for the measurement Free Chlorine (FCL), Sulfite (SO<sub>3</sub>), pH, and Temperature in compliance with USEPA 334.0 and ISO-7393 guidelines. The sensors advanced PCB offers built-in Free-Chlorine temperature and pH compensation (up to pH 9.0+) algorithms eliminating the need for a supplemental pH sensor and controller. Unique Bare-Gold electrode technology for Free chlorine and Sulfite measurement eliminates membranes and electrode solution replenishment commonly associated with conventional sensors. The ST-765SS Series has a uniquely designed flat bubble pH electrode design for reduced fouling potential. Reduce your maintenance and cost versus conventional electrochemical sensors by utilizing Pyxis replaceable Electrode Head (EH-765) for this sensor allowing for years of reliable service. The ST-765SS Series may be calibrated in-situ after cleaning via DPD or similar Sulfite wet chemistry test measurement of active sample.

The ST-765SS-DCL sensor offers a replaceable, front loading reference electrode assembly that has been independently developed by Pyxis Lab eliminating the shortcomings associated with membranes and gel replacement while offering reduced polarization time on startup with an electrode life span potential of up to 2-years. The flat front-end design of the ST-765SS-DCL makes this platform less prone to contamination or fouling and is easy to clean. The ST-765SS-DCL sensor body is composed of 304 stainless steel and is well suited for aggressive environments.

The ST-765SS-DCL sensor offers 2x 4-20mA and RS-485 Modbus outputs and is Bluetooth 5.0 enabled when used in conjunction with the MA-CR Bluetooth Adapter. This four-electrode composite sensor provides four measured parameters including free chlorine, sulfite pH and temperature with one sensor equipped with fully integrated 2x 4-20mA and RS-485 Modbus outputs. ST-765SS-DCL is uniquely designed for rapid and precise monitoring of de-chlorination (Chlorine-Scavenger) chemical treatment applications for both clean water (using ST-007 inline Tee Assembly) and dirty water (using FR-300-PLUS self-brushing flow assembly) as outlined in this manual.

### Key Features

- Real-Time pH + Sulfite (0-100ppm) + Free Chlorine (0-5ppm) Detection
- Dual 4-20mA Outputs (Sulfite + Free chlorine) and RS-485
- Bluetooth Enabled when used with MA-CR Adapter Wireless uPyxis Calibration
- Integrated RTD & pH Compensation to pH 9.0+ of the Oxidizer and Sulfite Value
- Replaceable EH-765 Reference Electrode Assembly – Simple Maintenance

### Common Applications

- Wastewater Effluent Chlorine Removal
- Cooling Tower Blowdown / Process Water / RO Feedwater Chlorine Removal



**ST-765SS-DCL**  
Free chlorine + Sulfite + pH Sensor



**EH-765**  
Replacement Electrode  
for all ST-765SS Series

## 1.1 Specifications

Item	ST-765SS-DCL
P/N	58444
Sensor Body Material	304SS
Free Chlorine Range	0.00-5.00 ppm
Free Chlorine Precision	± 0.01mg/L or 1% of the value w/pH compensation up to 9.0
Sulfite Range	0.00-100.00 ppm (auto-range)
Sulfite Precision	± 1.0mg/L or 1% of the value w/pH compensation up to 9.0+
pH Range	0-14
pH Precision	±0.01 pH
Sensor Power Supply	22 – 26VDC, Power Consumption 2W
Storage Temperature	-7 °C – 60 °C (20 – 140 °F)
Outputs	Dual Isolated 4 – 20 mA Analog Outputs + Isolated RS-485 Digital Output
Dimension (L x D)	Length 8.3 inch (210.8 mm), body diameter 1.4 Inch (35.6 mm)
Weight	530 g (1.16lbs)
Maximum Sensor Pressure	100 psi (6.9 Bar) – Sensor Only
Operating Temperature	4 °C – 49 °C (40 – 120 °F)
Wet Material	UPVC
Rating	IP67, Fully Dustproof & Waterproof
Selectivity	Non-Selective / Cross Sensitive to other Oxidizing Species
Compliance	EPA 334.0 / ISO 7393
Regulation	CE Marked / RoHS
Cables Included	MA-4.9CR Cable (8Pin Adapters – 1.5m) MA-1.5CR Cable (8 Pin Adapter / Flying Leads – 1.5m)
Typical Electrode Service Life	2 Years
Electrode Warranty	6 Months
Sensor Body Warranty	13 Months

### ST-007 INLINE TEE for CLEAN WATER APPLICATIONS *(Sold Separately)*

Item	ST-007
P/N	50700-A51
Sample Inlet Pressure	7.25 – 30 psi (0.05 – 0.2MPa)
Installation	ST-007 Inline Stainless-Steel Tee for CLEAN Water Applications
ST-007 Suggested Flow Rate	200 -400 mL/minute Flow Regulated via upstream Rotameter
ST-007 Sample Inlet/Outlet	1/4 - inch OD Compression

**\*NOTE\*** ST-007 is purchased separately and should be installed downstream of a Rotameter for **CLEAN-WATER APPLICATIONS** only.

### FR-300-PLUS for DIRTY WATER APPLICATIONS *(Sold Separately)*

Item	FR-300-PLUS
P/N	50700-A44
Sample Inlet Pressure	7.25 – 30 psi (0.05 – 0.2MPa)
Installation	FR-300-PLUS Self-Brushing Flow Reservoir for DIRTY Water Applications
FR-300-PLUS Suggested Flow Rate	200 – 800 mL/minute
FR-300-PLUS Sample Inlet /Outlet	3/8 - inch OD
FR-300-PLUS Operation	24VDC/2.5W Powered Constant ON Mode for Relay Control and RS-485
FR-300-PLUS Rotational Speed	200 RPM – Motorized Brush Preset for Constant Operation

**\*NOTE\*** FR-300-PLUS is purchased separately and **IS REQUIRED** for use in **DIRTY/INDUSTRIAL WATER APPLICATIONS**.



## 1.2 Unpacking the ST-765SS-DCL

Remove the instrument and accessories from the shipping container and inspect each item for any damage that may have occurred during shipping. Verify that all items listed on the packing slip are included. If any items are missing or damaged, please contact Pyxis Customer Service at [service@pyxis-lab.com](mailto:service@pyxis-lab.com)

## 1.3 Standard Accessories

- One **ST-765SS-DCL** Series sensor (P/N: 58444)
- Includes One **MA.4.9CR** – (Standard Cable Male-Female 8-Pin Adapters – 1.5m)
- Includes One **MA-1.5CR** – (Flying Lead Cable Female/Flying Lead 8-Pin Adapter – 1.5m)
- The full instrument manual is available for download at [Support Documents - Pyxis Lab, Inc. \(pyxis-lab.com\)](http://Support Documents - Pyxis Lab, Inc. (pyxis-lab.com))

## 1.4 Optional Accessories

The following optional accessories can be purchased via [order@pyxis-lab.com](mailto:order@pyxis-lab.com) or your preferred distributor.

Accessory Name	Item number
EH-765 <i>(Replacement Reference Electrode Head for ST-765SS Series)</i>	53601
ST-007 <i>(Inline Stainless Steel Tee Assembly for use with CLEAN WATER ONLY)</i>	50700-A51
HALL EFFECT FLOW METER <i>(Inline ¼-inch Hall Effect Flow Meter for sensor water sample flow measurement in CLEAN WATER ONLY)</i>	16008
FR-300-PLUS <i>(FR-300-PLUS Auto-Brushing Flow Assembly for use with ST-765 sensors in INDUSTRIAL WATER ONLY)</i>	50700-A44
FRP-300-1 <i>(Replacement Brush Head for FR-300-PLUS)</i>	50700-A49
MA-AC-7US <i>(110VAC Power Supply Adapter for FR-300-PLUS with USA Plug)</i>	26398
MA-AC-7EU <i>(230VAC Power Supply Adapter for FR-300-PLUS with EU/DIN Plug)</i>	28787
FLOWSWITCH-ROTAMETER FOR FR-300-PLUS USE <i>(Adjustable Contact Flow Switch Rotameter 6 - 60 Liter/Hour – Panel Mounted – 3/8-inch OD)</i>	21766
MICRO-ROTAMETER FOR ST-007 USE <i>(Adjustable Micro Rotameter 0 -1.0 Liter/Minute – ¼-inch OD)</i>	22876
MA-CR <i>(Bluetooth Adapter for use with 8-Pin Pyxis sensors &amp; uPyxis)</i>	MA-CR
MA-NEB <i>(USB Bluetooth Adapter for use with Laptop or Desktop for uPyxis)</i>	MA-NEB
MA-50CR <i>(Extension Cable-50 feet)</i>	50743
UC-50 <i>(Display + Data Logging Terminal)</i>	43007
SP-200 OxiPocket <i>(Pocket All-Oxidizing Disinfectants Colorimeter &amp; Fluorometer)</i>	50802
IK-765SS-DCL-B <i>(ST-765SS-DCL Sensor + FR-300-PLUS Flow Reservoir + UC-50 Display/Data Logger Panel Mounted)</i>	46758

## 2. Dimension

See dimension diagrams below for ST-765SS Series sensor with ST-007 (for clean water) and FR-300-PLUS (for industrial water).

### ST-765SS Series Dimensions (mm)

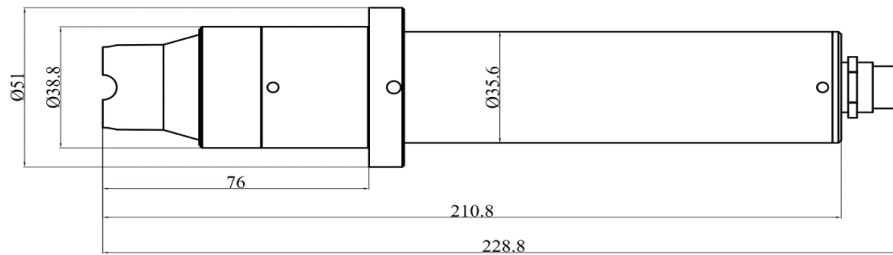

Figure 1. - Dimension of the ST-765SS (mm)

### ST-007 Flow Cell Dimensions (mm) – FOR CLEAN WATER USE ONLY

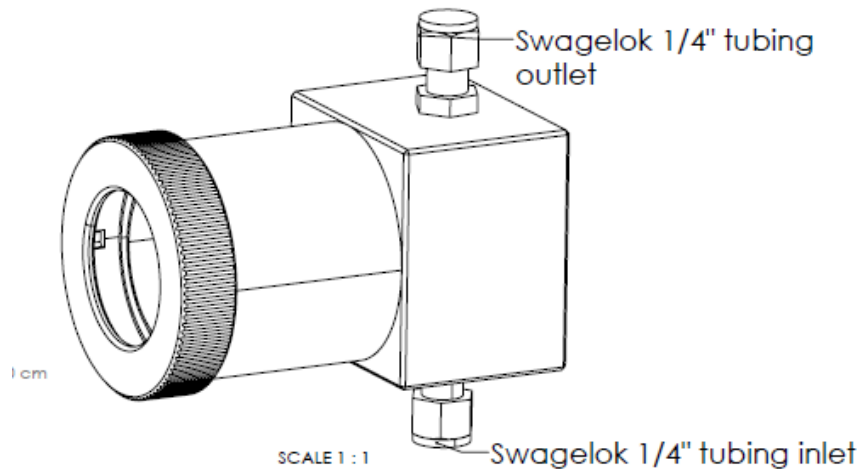

Figure 2. - ST-007 Inline Tee for ST-765SS-DCL use in CLEAN WATER APPLICATIONS ONLY

FR-300 Flow Cell Dimensions (mm) – FOR DIRTY/INDUSTRIAL WATER USE ONLY

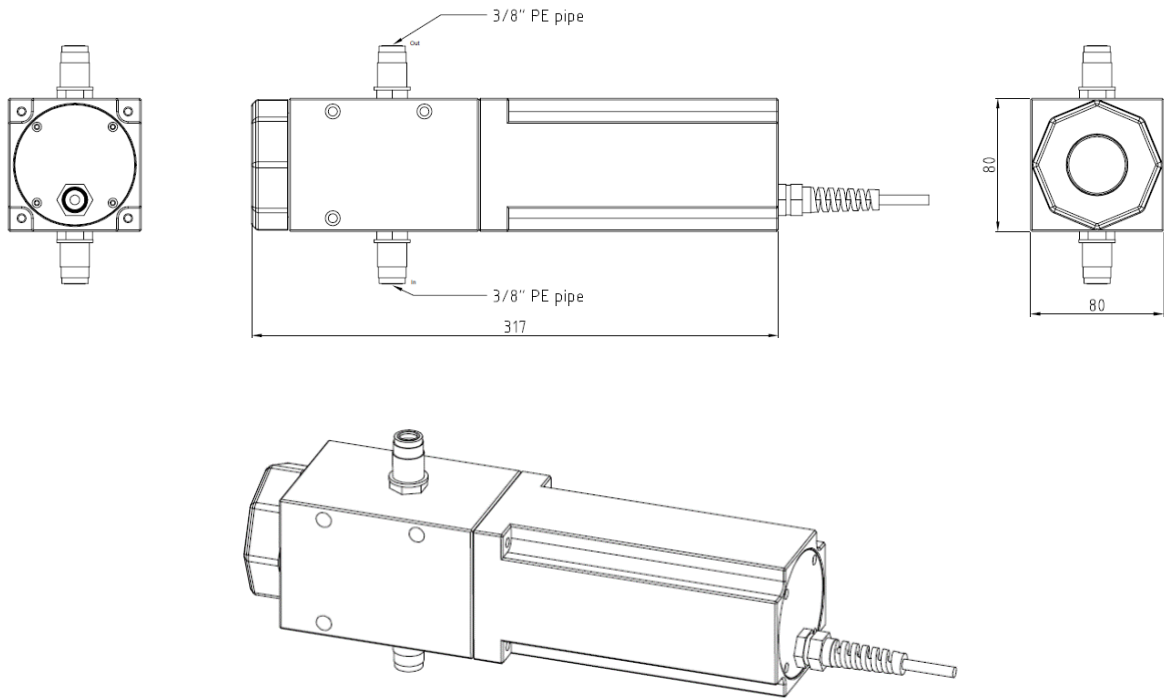

Figure 3. – FR-300-PLUS Flow cell for ST-765SS -DCL use in DIRTY / INDUSTRIAL WATER APPLICATIONS ONLY



### 3. ST-007 Installation & Operation for CLEAN WATER ONLY

**Application Use:** The ST-007 is a unique 316L stainless steel inline tee assembly specifically designed to safely house Pyxis inline sensors used in clean water applications only. The ST-007 should never be used in industrial or dirty water applications subject to suspended solids or particulate matter. The ST-007 is sold separately.

**Flow Regulation & Setting:** The ST-007 should be installed downstream of a user provided flow regulating device, such as a rotameter. Pyxis offers the inline Rotameter Assembly Kit (P/N 22876) for those desiring to purchase this accessory. Consistent clean water supply is critical to ensure the sensor does not become fouled. The ST-007 is ideally designed for prefiltered, pretreated makeup and feedwater (i.e. RO feedwater applications). The ST-765 series sensor when installed in the ST-007 inline tee assembly should be maintained at a consistent flow rate of 200-400mL/minute. This is critical for sensor repeatability. Alternatively, users may source their own flow regulating device for use upstream of the ST-765SS-DCL sensor.

**ST-007 & Sensor Orientation:** The ST-007 should be positioned in a way that flow enters the bottom and exits the top. This will ensure constant sensor electrode flooding. See image below for reference.

**Water Supply:** Inlet water pressure should be from 7.25 – 30 psi (0.05-0.2MPa) with an inlet feedwater line diameter of ¼-inch OD tubing.

**Drainage:** The ST-007 outlet is ¼-inch OD tubing outlet flow line should be diverted to drain or returned to an atmospheric tank/sump within the process itself for reuse.



ST-007 Installed with ST-765SS-DCL  
Downstream of Rotameter

#### 4. FR-300-PLUS Installation & Operation For INDUSTRIAL WATER ONLY

The Pyxis FR-300-PLUS is a magnetic coupling motorized brush flow assembly that provides an inline mechanical cleaning of the ST-765SS Series bare gold electrode enabling sensor accuracy in challenging industrial cooling and process waters. This unique device enhances the convective mass transport of the oxidizer or reducing agent analyte to the sensor electrode surface eliminating the need for precision flow control commonly required for other amperometric sensors on the market. The FR-300-PLUS also provides supplemental deactivation protection of the bare gold electrode for long life, stability, and precision accuracy in extremely challenging waters. The FR-300-PLUS is also designed to be utilized with a wide variety of alternative Pyxis inline sensors for a broad range of measurement. The FR-300-PLUS is sold separately.

The FR-300-PLUS contains a 'chemical injection port' in the assembly housing allowing for the optional injection of cleaning agents at the brush head for extremely challenged industrial waters containing fats, oils and grease. This port may also be used for the addition of Potassium Iodide for measurement of "True Total Chlorine". The FR-300-PLUS may be operated at a broad range of regulated sample flow from 200 and 800mL per minute with an inlet pressure of <30 psi. The FR-300-PLUS outlet flow line should be diverted to drain or returned to an atmospheric tank/sump within the process itself for reuse.

The FR-300-PLUS comes equipped with a magnetically coupled brush mounted in the liquid end of the flow reservoir. Operational life of the brush is typically 1+ year of service however this is application dependent based on water quality. The brush is held in place via magnetic coupling to the motor shaft for rapid tool-free removal and replacement. Brush replacement is outlined in the later sections of this document.

The FR-300-PLUS requires 24VDC power supply at approximately 2.5watts and can be directly connected to the OEM controller or may be powered by the optional Pyxis Lab outlet power supply adapter accessories available for both 110VAC and 230VAC outlet operation. (Purchased separately)

Pyxis Lab has developed a wide variety of pre-assembled analyzer panels incorporating the proprietary ST-765SS series sensor in combination with FR-300-PLUS self-brushing flow assembly and the UC-Series of Pyxis display and data logging terminals. Alternatively, the ST-765SS Series sensors and FR-300-PLUS self-brushing flow assembly may be utilized with OEM controllers, PLC's and DCS networks to providing a higher level of control for system chemistry applications while incorporating the unique Pyxis bare-gold sensor technology.

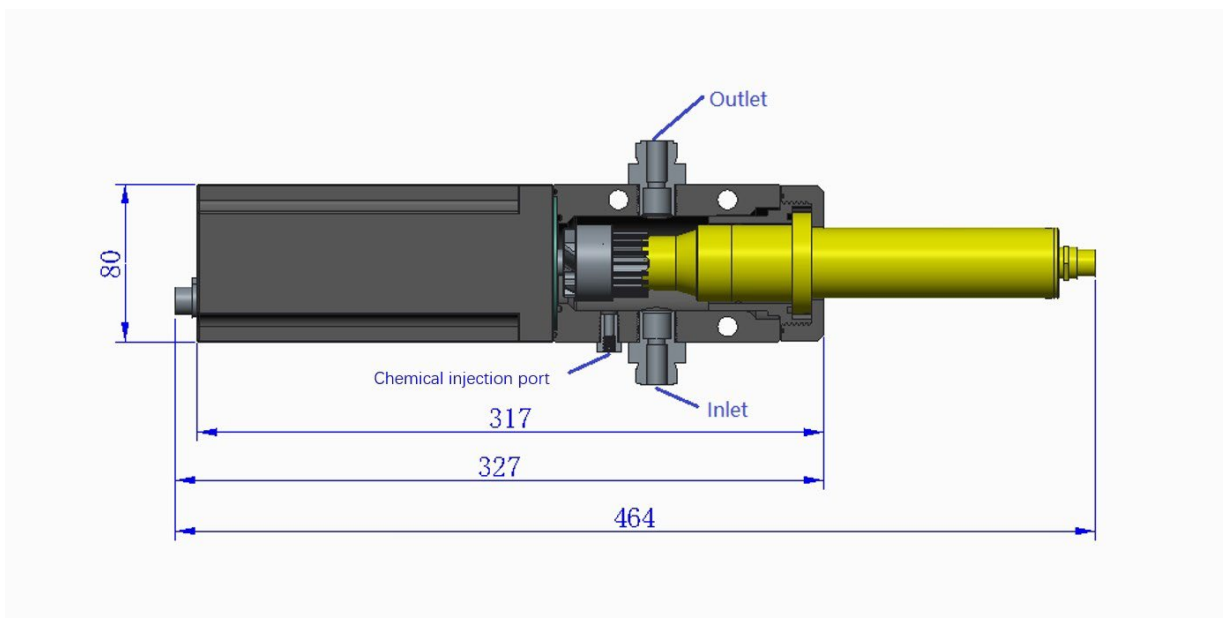

FR-300-01 Replacement Brushing Assembly Dimensions (mm) & Image

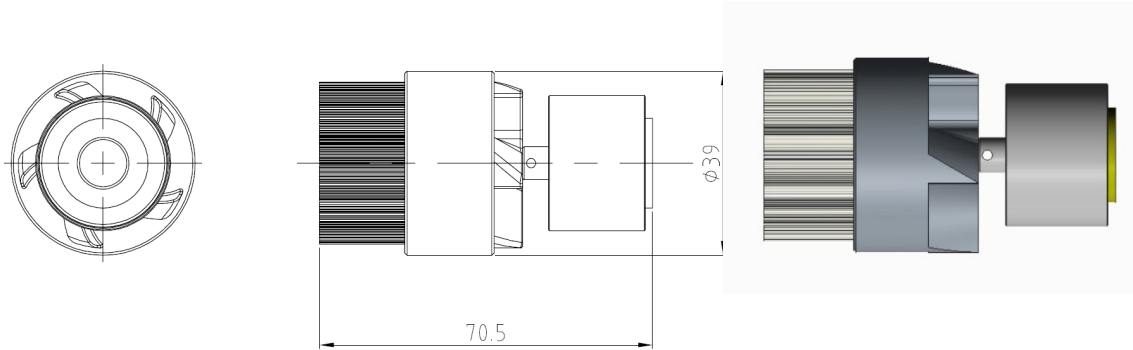

FR-300-01 Replacement Brushing Assembly Replacement Procedure

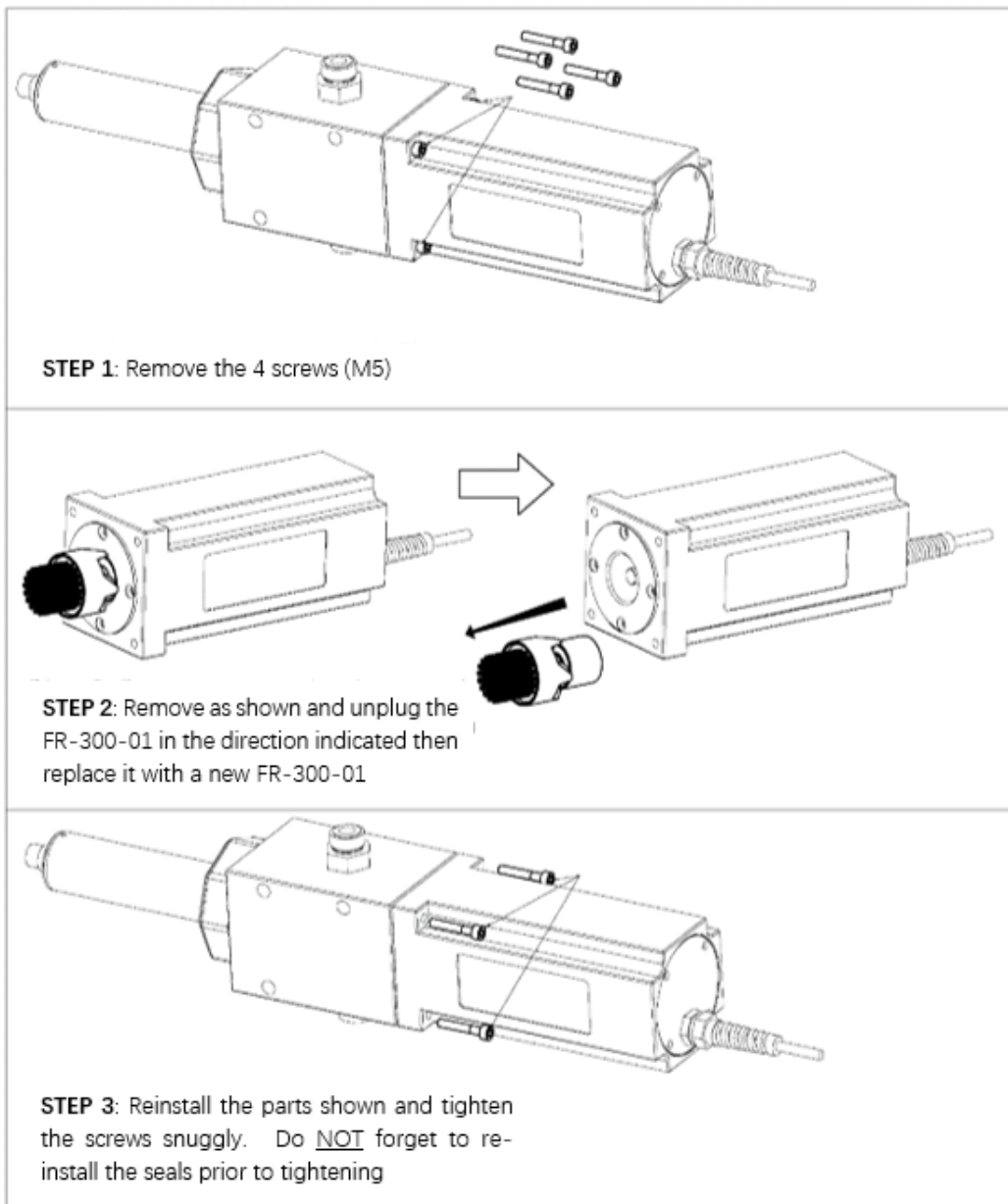

## FR-300-PLUS Installation & Operation Guidelines

**Mounting:** The FR-300-PLUS must be securely mounted to a back panel through the three (3) pre-drilled screw mounting holes in the reservoir body, with the Pyxis sensor aligned in a horizontal format as seen in the figure below.

**\*NOTE\*** Sensor may be aligned to the left or right as desired.

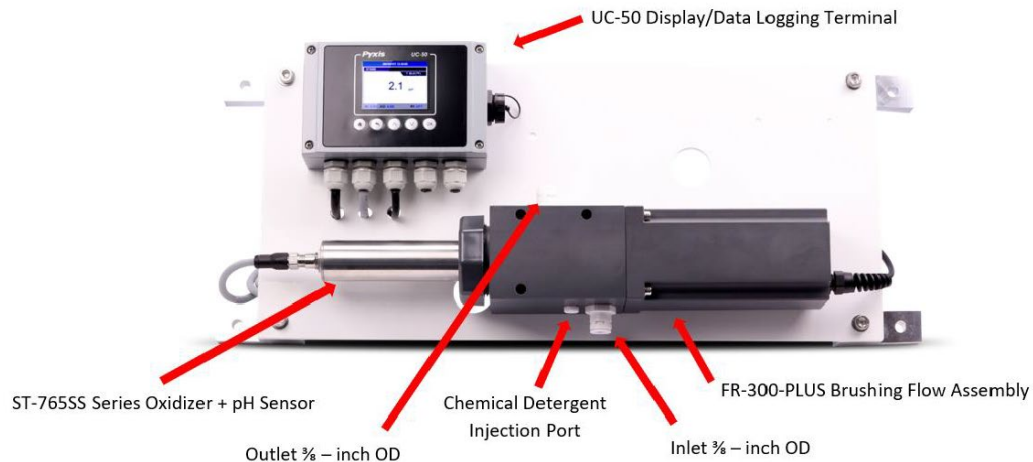

**Controller/PLC Provided Power Supply & Operation Mode:** The FR-300-PLUS is a stand-alone unit and requires 24VDC power supply to operate. Operating 100% of the time is the Pyxis suggested form of operation of the FR-300-PLUS, however some clients may desire to operate on a timed cycle or flow condition basis on desired cleanliness and system operation. This can be done via the connected controller as a powered relay activating the FR-300-PLUS on a timed sequence or system flow switch relay. See wiring section for FR-300-PLUS wiring.

**Outlet Provided Power Supply & Operation Mode:** For applications that require outlet provided power supply to the FR-300-PLUS, Pyxis offers **MA-AC-7US** (P/N 26398) and **MA-AC-7EU** (P/N 28787) power supply adapters in both 110VAC-USA (Type B) and 230VAC-EU (Type DIN) formats as optional accessories. These accessories allow the FR-300-PLUS to be outlet powered and operational 100% of the time. See order information section of this document for details.

**RS-485 Communication:** The FR-300-PLUS offers RS-485 connectivity which allows for rotational brush speed, operation and duration for those desiring precision control. Full time operation is suggested by Pyxis Lab for optimum sensor cleanliness.

**Inlet/Outlet Flow:** When mounted horizontally the inlet water flow to the FR-300-PLUS should enter the bottom of the unit via inlet port (3/8-inch OD) as seen in image above. The outlet water flow should exit the top of the unit via the outlet port (3/8-inch OD). The inlet water pressure should not exceed 30 psi. The outlet water should be returned to open sump at atmospheric pressure. The range of flow through the FR-300-PLUS should be consistently regulated between 200 and 800mL/minute. An inlet flow switch rotameter (P/N 21766) may be installed to verify and regulate inlet flow however, this is not absolutely necessary and a manual flow verification test is sufficient as long as flow remains consistently regulated. **\*NOTE\*** The FR-300-PLUS should be installed in a way to ensure the ST-765 series sensor remains flooded and wet regardless of flow condition.

**Calibration:** Once flow has been established and regulated, an in-situ slope calibration of the sensor can should be conducted using field analysis of the sample being measured. (i.e. DPD Free Chlorine) See ST-765SS Series Operation Manual for detailed calibration instructions.

**OxiPanel IK-765SS-DCL-B Free Chlorine + Sulfite + pH + Temperature Industrial Chlorine Scavenger Monitor**

For clients desiring a ‘turn-key’ monitoring solution for challenging/industrial water to monitor Chlorine-Scavenger chemical treatment applications, Pyxis Lab offers the OxiPanel IK-765SS-DCL-B. The IK-765SS-DCL-B series offers highly accurate, real-time measurement, display and data-logging of residual Free-Chlorine (FCL), Sulfite (SO<sub>3</sub>), pH and Temperature utilizing proprietary Pyxis Lab smart sensor technology, coupled with a Pyxis UC-50 micro-display and data logging terminal. The IK-765SS-DCL also incorporates a uniquely designed automated mechanical brush flow assembly (FR-300-PLUS) which is directly controlled via the UC-50 display to maintain optimum sensor electrode cleanliness in ‘dirty’ water applications.

The UC-50 is a microprocessor display/data-logging terminal that has been preconfigured to connect Pyxis inline sensors with fully integrated calibration, scaling and measurement protocol. The user may also configure and calibrate the output signal through the UC-50 controller's screen.

Item	P/N	Description
OxiPanel IK-765SS-DCL-B	46758	ST-765SS-DCL Sensor + FR-300 PLUS Flow Reservoir + UC-50 Display/Data Logger

**Image and Dimensions of IK-765SS Series (mm)**

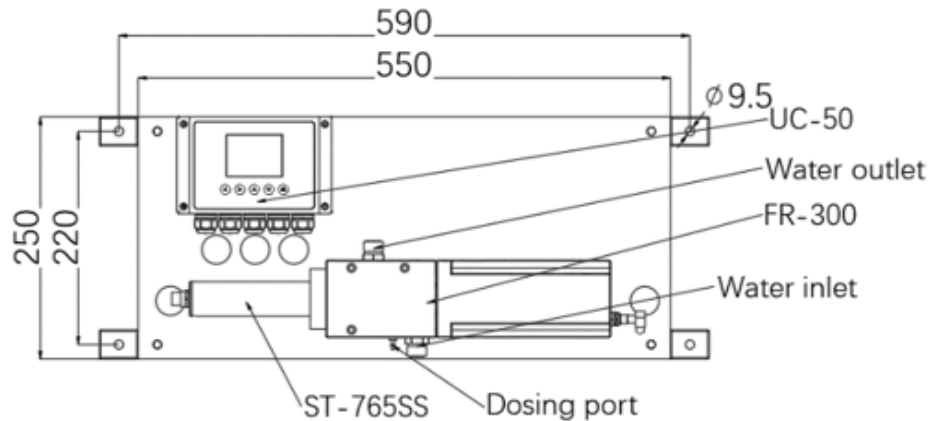



## 5. Wiring of ST-765SS-DCL Sensor & FR-300-PLUS Flow Reservoir

### ST-765SS-DCL Wiring Instructions

Follow the wiring table below to connect the ST-765SS-DCL sensor to a controller or PLC. **\*NOTE\*** All Pyxis sensors provide a passive 4-20mA output signal, they are NOT LOOP POWERED. 24VDC+ power supply and 4- 20mA+ signal are independent of each other in all Pyxis Lab sensors. If the 24V power ground and the 4-20 mA-return in the controller are internally connected (non- isolated 4-20mA input), it is unnecessary to connect the 4-20 mA- (Gray wire) to the 4-20 mA negative terminal in the controller.

Wire Color	Designation
Red	24 V +
Brown	Power Ground
Green	Shield, solution ground
Gray	4-20 mA -
White	4-20 mA + for Free Chlorine
Pink	4-20 mA + for Sulfite
Blue	RS-485 A
Yellow	RS-485 B
Black	Shield, solution ground

**\*NOTE\*** Pyxis recommends the 24VDC power supply to the ST-765 series sensor be turned OFF for systems that experience extended periods of stagnant water conditions exceeding one hour in duration. Upon sensor power-up, the ST-765 series will complete a 5-minute electrode initialization to remove any oxide layer from the gold electrode which accumulates during stagnation. The sensor will output 1mA for oxidizer/reducer during this initialization process and return to its normal reading with 4-20mA output once complete.

ST-765SS-DCL Sensor 4-20mA Scaling		
Unit of Measure	4mA Value	20mA Value
Sulfite	0.00 ppm	100.00 ppm
Free Chlorine	0.00 ppm	5.00 ppm

### FR-300-PLUS Wiring Instructions

Follow the wiring table below to connect the FR-300-PLUS to a controller or the Pyxis UC-50 via 24VDC and RS-485 Modbus. Alternatively, any OEM controllers capable of providing 24VDC power supply may also be used. The FR-300-PLUS may be operated 100% of the time with no issue, simply by providing the unit 24VDC power supply. Some users may also consider operating the FR-300-PLUS as desired in an ON/OFF relay format based on their application needs. **NOTE** – The FR-300-PLUS may be operated via 110VAC or 230VAC outlet power supply by utilizing optional Pyxis power supply adapter cables with plug purchased separately. See the Optional Accessories Section 1.4 of this document for details.

Pin #	Wire Color	Designation
1	Red	24V
2	Black	0V
3	Blue	485A
5	Yellow	485B
7	Silver	Ground
4	White	NA
6	Green	NA



## 6. Calibration and Diagnosis

The ST-765SS Series sensors are rigorously calibrated before leaving the factory. As such, users do not need to calibrate the sensor for a period of three months or up to one year if the sensor is maintained in clean condition. Users can however calibrate the sensor according to their application needs and as desired using the MA-CR Bluetooth adapter and uPyxis APP for mobile or desktop devices.

### 6.1 Calibration and Diagnosis by uPyxis Mobile App

Connect and power the ST-765SS sensor using the MA-CR Pyxis Bluetooth adapter (P/N: MA-CR) as shown in the following connection diagram. The power should be sourced from a 24 VDC power terminal of a controller. If a controller is not available, please purchase a 24VDC power supply.



MA-CR Bluetooth Adapter

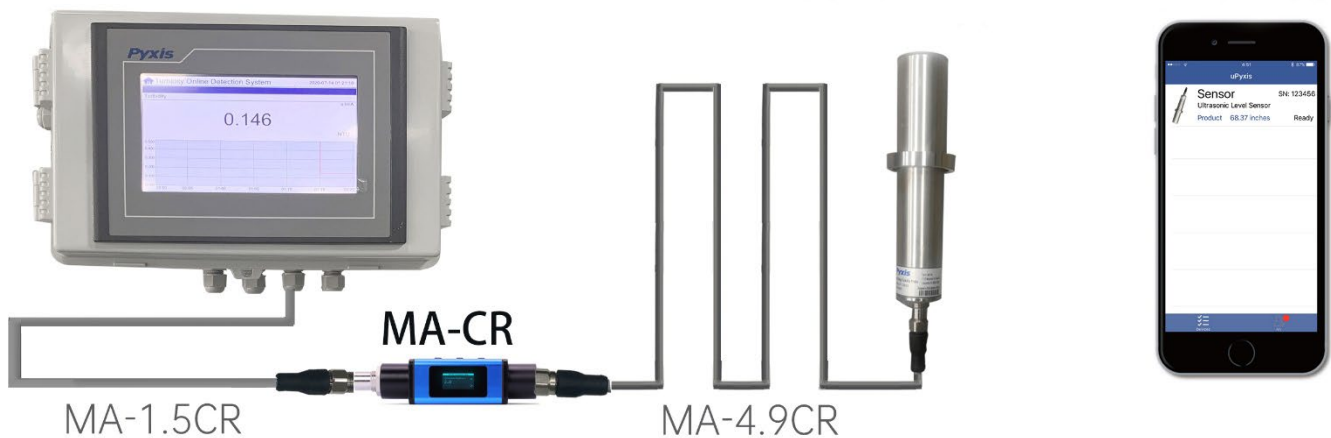

Figure 4. - Power the ST-765SS via controller with the MA-CR Bluetooth Adapter inserted between both



Download and install the uPyxis app from **Apple Store** or **Google Play**. Turn on the Bluetooth in the smart device (please do not pair your device Bluetooth to uPyxis, the app will do the pairing). Open the uPyxis app in the device. Swipe down to refresh the screen to scan the available Pyxis Bluetooth devices. The discovered devices will be listed as shown in *Figure 6*.

Tap the discovered ST-765SS sensor to connect to the sensor. The uPyxis app can identify the sensor type if multiple Pyxis sensors are discovered in the scan.

As shown in *Figure 6*, in the calibration page of uPyxis after connected to the sensor via the MA-CR Bluetooth adapter the current Free Chlorine, Sulfite, pH and temperature values will be displayed. Nine functional tabs of each are available in this page: Free Chlorine Zero/Slope Calibration, Sulfite Zero/Slope Calibration, pH Low Calibration, pH 7 Calibration, pH High calibration and Free Chlorine/Sulfite 4-20mA Span.

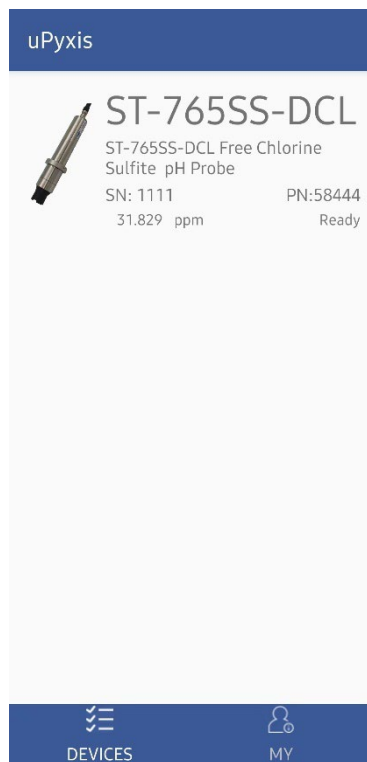

Figure 5 - ST-765SS Discovered via Bluetooth

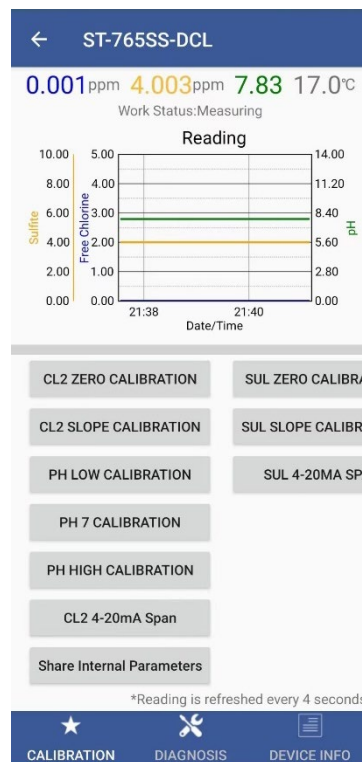

Figure 6 - Calibration Page

### 6.1.2 Free Chlorine Calibration w/uPyxis MOBILE

The oxidizer measurement module of ST-765SS Series is rigorously calibrated before leaving the factory. If calibration is required, users can perform single-point, or two-point calibration as required. The oxidizer measurement module of ST-765SS-DCL may be calibrated for Zero and Slope Calibration using a known standard / sample tested and measured by DPD wet chemistry methods.

### 6.1.1.2 Free Chlorine – Single Point Calibration Procedure

The ST-765SS Series must be slope calibrated in the ST-007 (for clean water) or the FR-300-PLUS flow reservoir (for industrial water) used with the sensor and must have **CONSISTENT** flow within the specified range as outlined in the specifications section 1.0 of this manual. Determine the Free Chlorine concentration in ppm of the sample water taken from the sensor flow tee/reservoir output sample by using the DPD method on a portable or laboratory colorimeter (i.e. Pyxis SP-200 / SP-800 / SP-910 or similar). Launch the uPyxis app and connect to the ST-765SS Series sensor. Tap **SLOPE CALIBRATION**. Enter the Free Chlorine concentration determined by the DPD method in the dialog window as shown in Figure 7. Please make sure that the sensor reading has been stable for at least 10 minutes before calibration. For best results, the concentration of the bromine sample flow standard should be in the range of 0.1 to 5.0 ppm.

### 6.1.1.3 Free Chlorine – Two-Point Calibration Procedure

*Zero-point Calibration:* Launch the uPyxis app and connect to the ST-765SS sensor. Remove the ST-765SS sensor from the ST-007 tee or the FR-300-PLUS flow reservoir and place the sensor into a beaker containing Pyxis Zero-oxidizer Standard Solution (P/N 21022), then tap **CL2 ZERO CALIBRATION** in the uPyxis app. Please allow sufficient time (a few minutes) for the sensor to stabilize before performing the calibration. **\*NOTE\*** Users may also use up to 100 us/cm conductivity standard as a ZERO CALIBRATION solution.

*Slope-point Calibration:* Insert the ST-765SS Series sensor back into the ST-007 tee or the FR-300-PLUS flow reservoir and reestablish sample flow. The ST-765SS-DCL sensor must be slope calibrated for Free-Chlorine based on DPD test method results of the actual system sample while installed in the ST-007 tee or the FR-300-PLUS flow reservoir used with the sensor and exposed to consistent system sample flow for the installation method being used as outlined in the specifications section 1.0 of this manual. Determine the free chlorine concentration by using DPD method on a portable or laboratory colorimeter (i.e.. Pyxis SP-200 / SP-800 / SP-910 or similar). Tap **CL2 SLOPE CALIBRATION** and enter the test result value in Calibration Screen as shown in Figure 7. Please make sure that the sensor reading has been stable for at least 10 minutes before calibration. For best results, the concentration of the Free Chlorine sample flow standard should be in the range of 0.1 to 5.0 ppm.

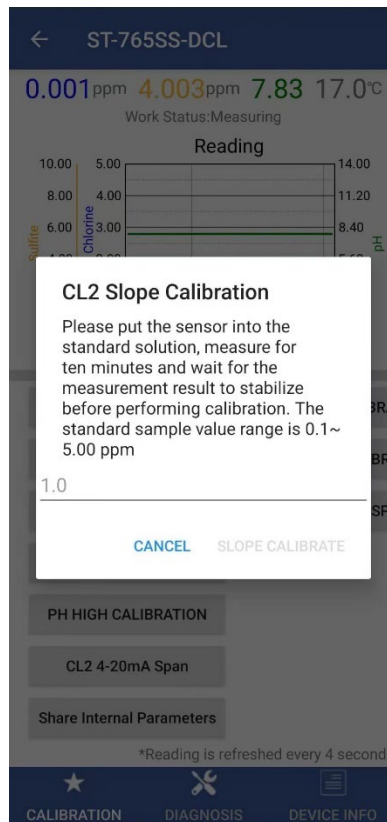

Figure 7 — Enter Free Chlorine Concentration to begin Slope Calibration

## 6.1.2 Sulfite Calibration w/uPyxis MOBILE

The measurement module of the ST-765SS-DCL sensor is thoroughly calibrated at the Pyxis Lab factory using an Argon saturated water sample containing a precise residual concentration of Sulfite. If calibration is required, users can perform single-point or two-point calibration as required.

### 6.1.2.1 Sulfite - Single Point Calibration Procedure

The ST-765SS-DCL sensor must be slope calibrated for Sulfite based on titration test method results of the actual system sample while installed in the ST-007 or FR-300-PLUS flow reservoir and exposed to **CONSISTENT** system sample flow with the specified range as outlined in the specifications section 1.0 of this manual. Determine the Sulfite concentration in ppm of the sample water taken from the sensor flow tee/reservoir output sample by using the of the titration method, colorimeter or fluorometer (i.e. Pyxis SP-800 / SP-910 or Hach DR1300). Once you have tested and confirmed the Sulfite concentration value in the active (flowing) sample, Tap **SUL SLOPE CALIBRATION** and enter the test result value of the portable or laboratory colorimeter in Calibration Screen as shown in Figure 8.

### 6.1.2.2 Sulfite - Two-Point Calibration Procedure

**Zero-point Calibration:** Launch the uPyxis app and connect to the ST-765SS sensor. Remove the ST-765SS sensor from the FR-300-PLUS flow reservoir and place the sensor into a beaker containing Pyxis Zero-oxidizer Standard Solution (P/N 21022), then tap **SUL ZERO CALIBRATION** in the uPyxis app. Please allow sufficient time (a few minutes) for the sensor to stabilize before performing the calibration. **\*NOTE\*** Users may also use up to 100 us/cm conductivity standard as a ZERO CALIBRATION solution.

**Slope-point Calibration:** Insert the ST-765SS Series sensor back into the ST-007 tee or the FR-300-PLUS flow reservoir and reestablish sample flow. The ST-765SS-DCL sensor must be slope calibrated for Sulfite based on test method results of the actual system sample while installed in the ST-007 tee or the FR-300-PLUS flow reservoir used with the sensor and exposed to consistent system sample flow for the installation method being used as outlined in the specifications section 1.0 of this manual. Determine the Sulfite concentration using titration method, colorimeter or fluorometer (i.e. Pyxis SP-800 / SP-910 or Hach DR1300). Once you have tested and confirmed the Sulfite concentration value in the active (flowing) flow tee assembly, Tap **SUL SLOPE CALIBRATION** and enter the test result value of the portable or laboratory colorimeter in Calibration Screen as shown in Figure 8.

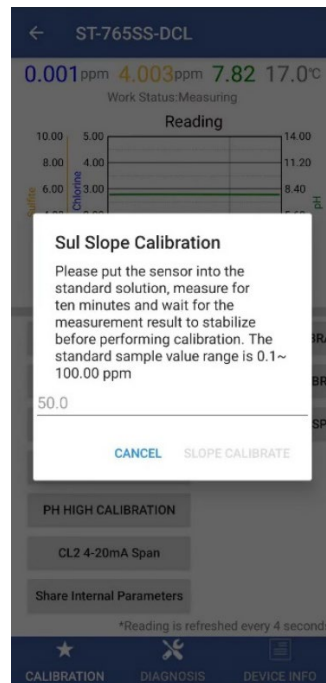

Figure 8 – Enter Sulfite Concentration to begin Slope Calibration

### 6.1.3 pH Calibration w/uPyxis MOBILE

Remove and place the sensor in a low pH (i.e. 4.0) calibration standard solution and tap **pH LOW CALIBRATION** in the uPyxis app. Measure for 1 minute and wait for the measurement result to stabilize before performing calibration, the low pH calibration standard value range acceptable for this step is 1.00-6.00 pH.

Place the sensor into the pH 7.0 calibration standard solution and tap **pH 7 CALIBRATION** in the uPyxis app. Measure for 1 minute and wait for the measurement result to stabilize before performing calibration.

Place the sensor in a high pH (i.e. 10.0) calibration standard solution and tap **pH HIGH CALIBRATION** in the uPyxis app. Measure for 1 minute and wait for the measurement result to stabilize before performing calibration, the high pH calibration standard value range acceptable for this step is 8.00-13.00 pH.

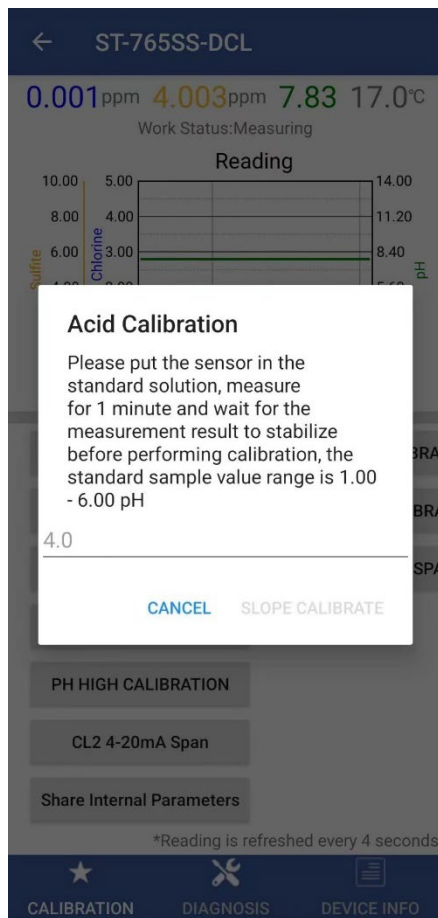

Figure 9  
Enter Low-pH Concentration for Calibration

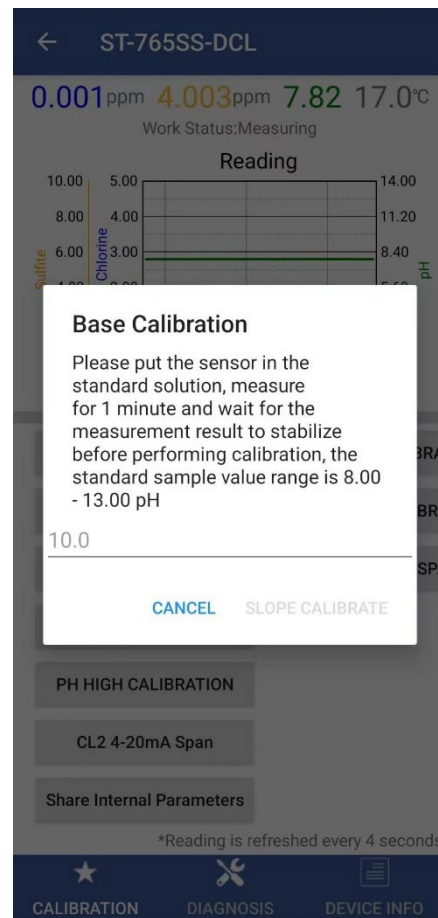

Figure 10  
Enter High-pH Concentration for Calibration



### 6.1.4 4-20mA Span w/uPyxis MOBILE

The 4–20mA output of the ST-765SS-DCL sensor is scaled as:

- Sulfite:
  - 4 mA = 0 ppm
  - 20 mA = 100 ppm
- Free Chlorine:
  - 4 mA = 0 ppm
  - 20 mA = 5 ppm

Tap **4-20mA SPAN** to change the free chlorine or sulfite value corresponding to the 20mA output to a lower value as seen in *Figure 11 and 12*. **\*NOTE\*** The 4-20mA Span feature allows users to REDUCE the upper 20mA output scale only. You cannot INCREASE the upper limit of the sensor beyond the range of the sensor.

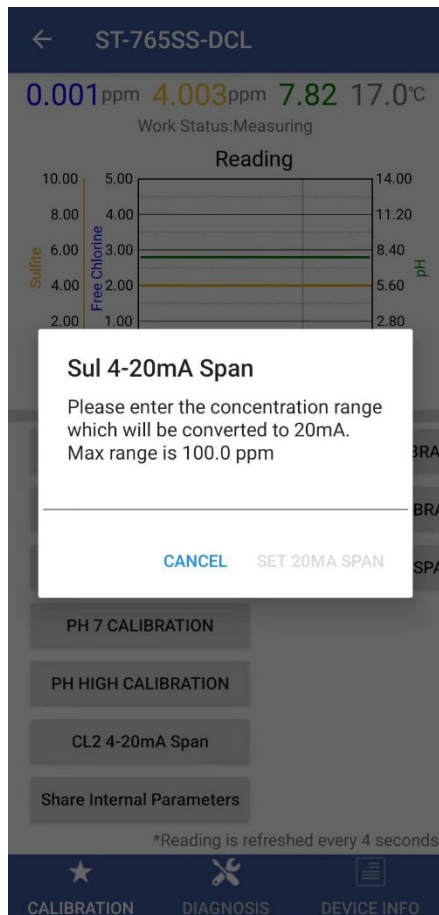

Figure 11 - Adjust 20mA Setting for Sulfite (<100 ppm)

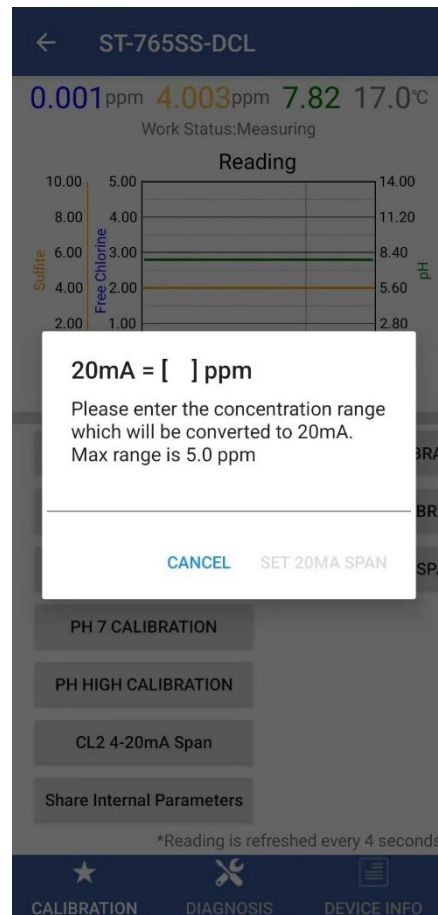
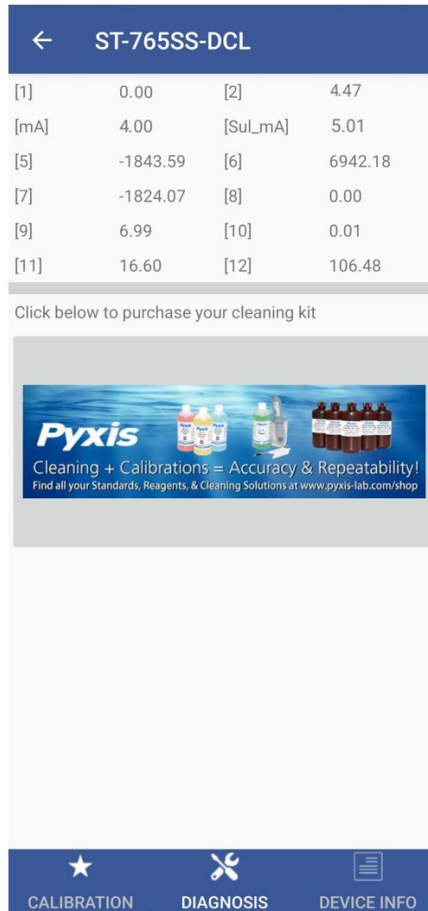

Figure 12 - Adjust 20mA Setting for Free Chlorine (<5 ppm)

### 6.1.5 Diagnosis w/uPyxis MOBILE

Tap **Diagnosis** in the bottom of the app page to launch the diagnosis page *Figure 13*.

In this page, the raw data measured by the sensor is displayed. To help troubleshooting possible issues with the sensor, please save images of these data when the sensor is respectively placed in a clean water (tap water or deionized water), in a pH standard solution, and in the sample that the sensor is intended for. This data may be exported from the uPyxis APP via email to [service@pyxis-lab.com](mailto:service@pyxis-lab.com) for technical support.



← ST-765SS-DCL			
[1]	0.00	[2]	4.47
[mA]	4.00	[Sul_mA]	5.01
[5]	-1843.59	[6]	6942.18
[7]	-1824.07	[8]	0.00
[9]	6.99	[10]	0.01
[11]	16.60	[12]	106.48

Click below to purchase your cleaning kit



CALIBRATION    **DIAGNOSIS**    DEVICE INFO

*Figure 13 - Diagnostic Interface*

## 6.2 Calibration and Diagnosis by uPyxis Desktop App

1) Download and install uPyxis Desktop APP from

<https://upyxis.pyxis-lab.com.cn/release/pc/uPyxis.Setup-latest.zip>

2) Connect a USB Type-C cable to the port at the bottom of the MA-CR and to the USB port of the laptop or computer. This will provide power the MA-CR from the laptop/computer. Connect the MA-CR to the ST-765SS-DCL sensor. The MA-CR Bluetooth adapter will boost the 5V of the regular USB to 24V to power the sensor for use with uPyxis Desktop.



MA-CR Bluetooth Adapter – Bottom USB-C

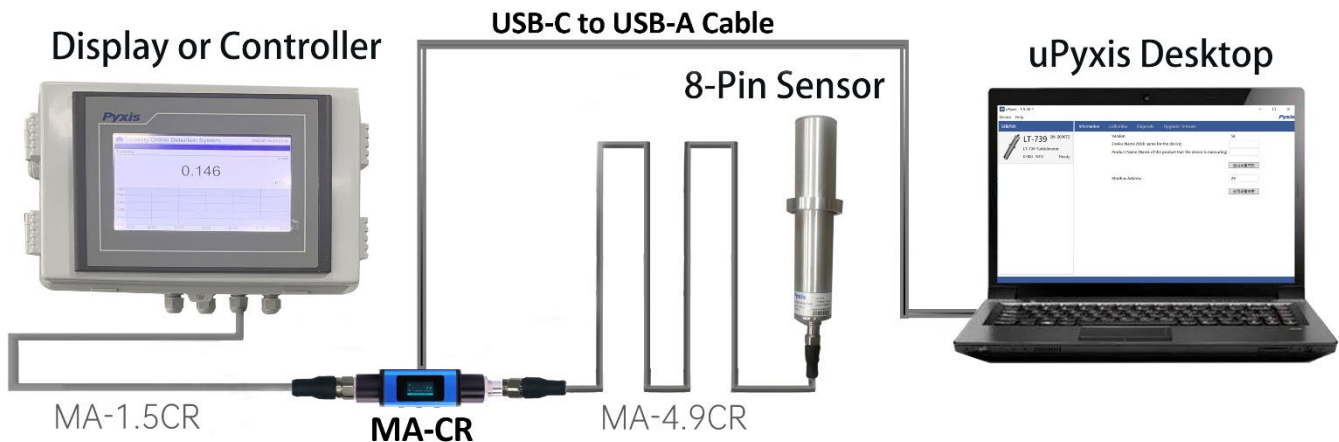

Figure 14 – MA-CR Connected to Sensor & Laptop

3) Set the MA-CR to operate in USB Mode by following the steps below.

- a. Once the MA-CR screen is powered Press ◀ or ▶ until you arrive at (USB to RS485) screen.
- b. Press the **OK** Button.
- c. Follow Prompts below to Enable USB feature. Once enabled, you may connect to uPyxis.



- 4) Open the desktop uPyxis APP.
- 5) Click Device to launch the connection option menu.
- 6) Select Connect via USB-RS485 (*Figure 15*).
- 7) Select the Comm Port to make a connection. Normally only one Comm port is identified by uPyxis (*Figure 16*). If more than one Comm port listed in the selection dropdown, you may try to select each one to see if a connection can be made. Alternatively, you may use the Windows Device Manager to identify the Comm Port that the Pyxis USB adapter is using.

After the connection is established, the ST-765SS sensor series number and free chlorine values reading will be displayed on the left of the information page *Figure 17*. In this page, a nickname can be assigned to the sensor. The sensor Modbus address can also be changed if desired. Click Calibration to launch the calibration page *Figure 18*.

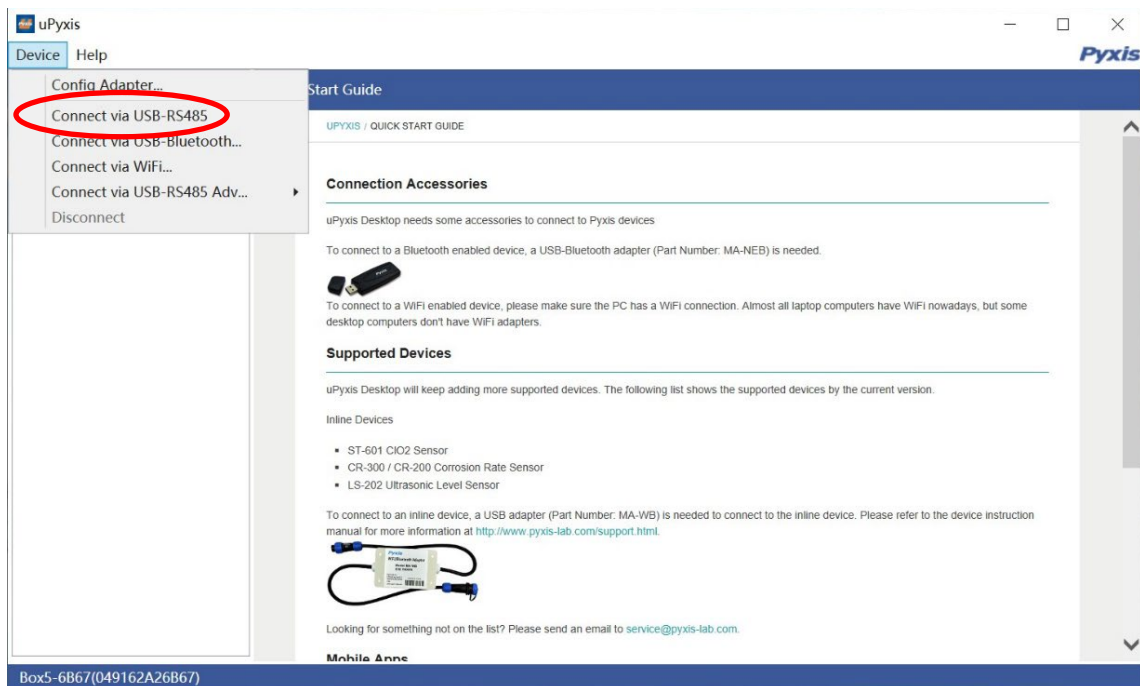

*Figure 15 - Connection Options*

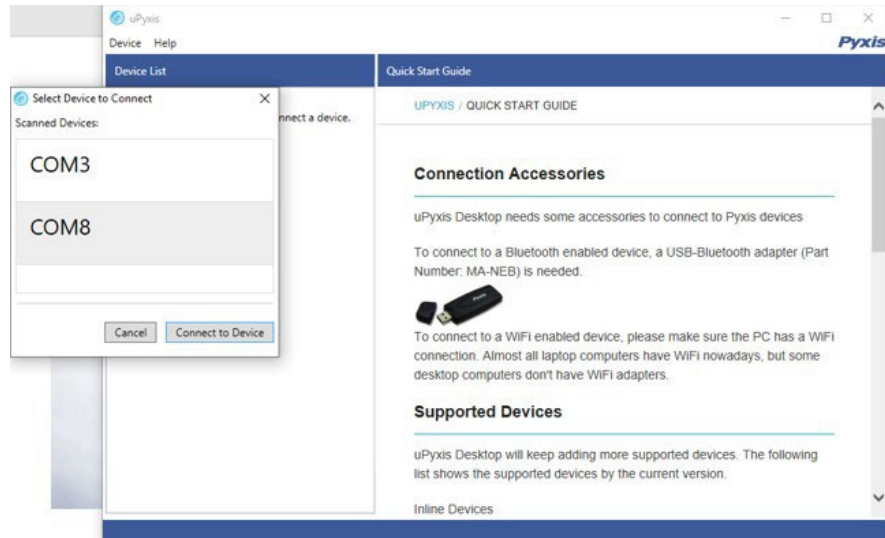

Figure 16 - Select a Comm port

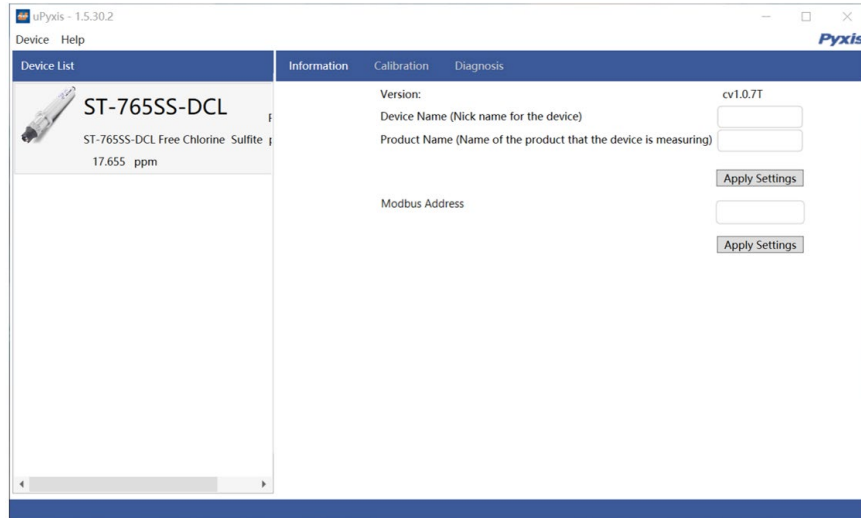

Figure 17 - Connected to ST-765SS-DCL sensor and information page

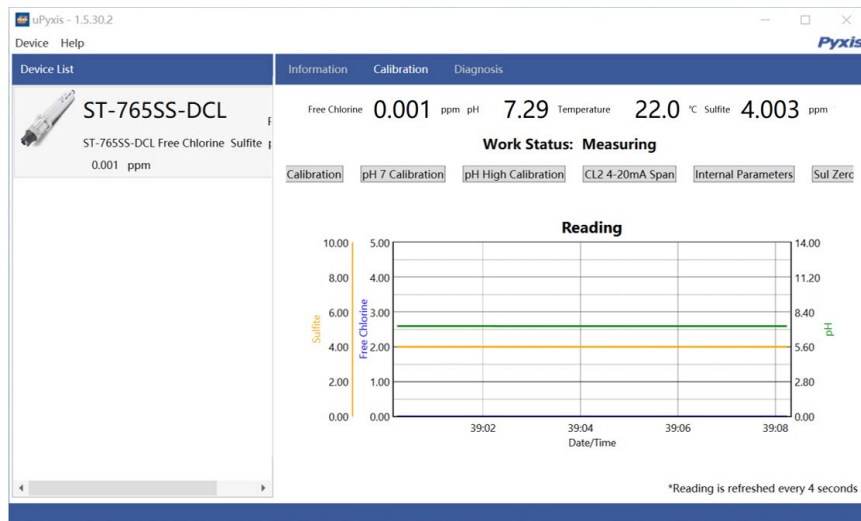

Figure 18 - Calibration Page

## 6.2.1 Free Chlorine Calibration w/uPyxis DESKTOP

The oxidizer measurement module of ST-765SS Series is rigorously calibrated before leaving the factory. If calibration is required, users can perform single-point, or two-point calibration as required. The oxidizer measurement module of ST-765SS-DCL may be calibrated for Zero and Slope Calibration using a known standard / sample tested and measured by DPD wet chemistry methods.

### 6.2.1.1 Free Chlorine - Single Point Calibration Procedure

The ST-765SS Series must be slope calibrated in the ST-007 (for clean water) or the FR-300-PLUS flow reservoir (for industrial water) used with the sensor and must have **CONSISTENT** flow within the specified range as outlined in the specifications section 1.0 of this manual. Determine the Free Chlorine concentration in ppm of the sample water taken from the sensor flow tee/reservoir output sample by using the DPD method on a portable or laboratory colorimeter (i.e., Pyxis SP-200 / SP-800 / SP-910 or similar). Launch the uPyxis app and connect to the ST-765SS Series sensor. Tap **SLOPE CALIBRATION**. Enter the Free Chlorine concentration determined by the DPD method in the dialog window as shown in Figure 19. Please make sure that the sensor reading has been stable for at least 10 minutes before calibration. For best results, the concentration of the bromine sample flow standard should be in the range of 0.1 to 5.0 ppm.

### 6.2.1.2 Free Chlorine - Two- Point Calibration Procedure

*Zero-point Calibration:* Launch the uPyxis app and connect to the ST-765SS sensor. Remove the ST-765SS sensor from the ST-007 tee or the FR-300-PLUS flow reservoir and place the sensor into a beaker containing Pyxis Zero-oxidizer Standard Solution (P/N 21022), then tap **CL2 ZERO CALIBRATION** in the uPyxis app. Please allow sufficient time (a few minutes) for the sensor to stabilize before performing the calibration. **\*NOTE\*** Users may also use up to 100 us/cm conductivity standard as a ZERO CALIBRATION solution.

*Slope-point Calibration:* Insert the ST-765SS Series sensor back into the ST-007 tee or the FR-300-PLUS flow reservoir and reestablish sample flow. The ST-765SS-DCL sensor must be slope calibrated for Free-Chlorine based on DPD test method results of the actual system sample while installed in the ST-007 tee or the FR-300-PLUS flow reservoir used with the sensor and exposed to consistent system sample flow for the installation method being used as outlined in the specifications section 1.0 of this manual. Determine the free chlorine concentration by using DPD method on a portable or laboratory colorimeter (i.e., Pyxis SP-200 / SP-800 / SP-910 or similar). Tap **CL2 SLOPE CALIBRATION** and enter the test result value in Calibration Screen as shown in Figure 19. Please make sure that the sensor reading has been stable for at least 10 minutes before calibration. For best results, the concentration of the Free Chlorine sample flow standard should be in the range of 0.1 to 5.0 ppm.



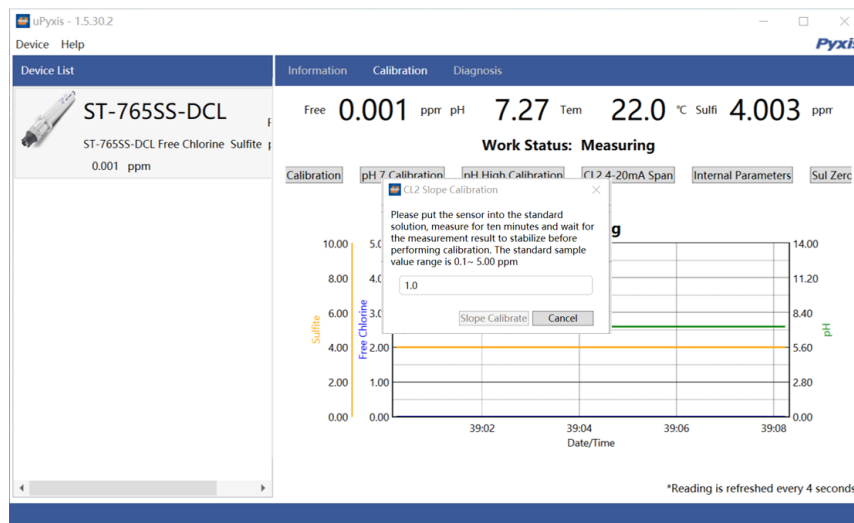

Figure 19 - Slope Calibration

## 6.2.2 Sulfite Calibration w/uPyxis DESKTOP

The measurement module of the ST-765SS-DCL sensor is thoroughly calibrated at the Pyxis Lab factory using an Argon saturated water sample containing a precise residual concentration of Sulfite. If calibration is required, users can perform single-point, or two-point calibration as required.

### 6.2.2.1 Sulfite - Single Point Calibration Procedure

The ST-765SS-DCL sensor must be slope calibrated for Sulfite based on titration test method results of the actual system sample while installed in the ST-007 or FR-300-PLUS flow reservoir and exposed to **CONSISTENT** system sample flow with the specified range as outlined in the specifications section 1.0 of this manual. Determine the Sulfite concentration in ppm of the sample water taken from the sensor flow tee/reservoir output sample by using the of the titration method, colorimeter or fluorometer (i.e. Pyxis SP-800 / SP-910 or Hach DR1300). Once you have tested and confirmed the Sulfite concentration value in the active (flowing) sample, Tap **SUL SLOPE CALIBRATION** and enter the test result value of the portable or laboratory colorimeter in Calibration Screen as shown in Figure 20.

### 6.2.2.2 Sulfite - Two-Point Calibration Procedure

***Zero-point Calibration:*** Launch the uPyxis app and connect to the ST-765SS sensor. Remove the ST-765SS sensor from the FR-300-PLUS flow reservoir and place the sensor into a beaker containing Pyxis Zero-oxidizer Standard Solution (P/N 21022), then tap **SUL ZERO CALIBRATION** in the uPyxis app. Please allow sufficient time (a few minutes) for the sensor to stabilize before performing the calibration. **\*NOTE\*** Users may also use up to 100 us/cm conductivity standard as a ZERO CALIBRATION solution.

***Slope-point Calibration:*** Insert the ST-765SS Series sensor back into the ST-007 tee or the FR-300-PLUS flow reservoir and reestablish sample flow. The ST-765SS-DCL sensor must be slope calibrated for Sulfite based on test method results of the actual system sample while installed in the ST-007 tee or the FR-300-PLUS flow reservoir used with the sensor and exposed to consistent system sample flow for the installation method being used as outlined in the specifications section 1.0 of this manual. Determine the Sulfite concentration using titration method, colorimeter or fluorometer (i.e.. Pyxis SP-800 / SP-910 or Hach DR1300). Once you have tested and confirmed the Sulfite concentration value in the active (flowing) flow tee assembly, Tap **SUL SLOPE CALIBRATION** and enter the test result value of the portable or laboratory colorimeter in Calibration Screen as shown in Figure 20.

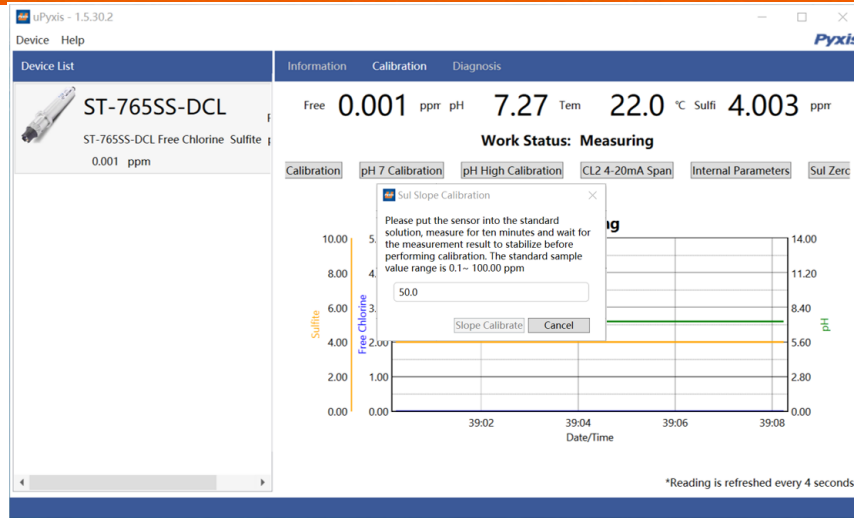

Figure 20 - Slope Calibration

### 6.2.3 pH Calibration w/uPyxis DESKTOP

Remove and place the sensor in a low pH (i.e. 4.0) calibration standard solution and tap **pH LOW CALIBRATION** in the uPyxis app. Measure for 1 minute and wait for the measurement result to stabilize before performing calibration, the low pH calibration standard value range acceptable for this step is 1.00-6.00 pH.

Place the sensor into the pH 7.0 calibration standard solution and tap **pH 7 CALIBRATION** in the uPyxis app. Measure for 1 minute and wait for the measurement result to stabilize before performing calibration.

Place the sensor in a high pH (i.e. 10.0) calibration standard solution and tap **pH HIGH CALIBRATION** in the uPyxis app. Measure for 1 minute and wait for the measurement result to stabilize before performing calibration, the high pH calibration standard value range acceptable for this step is 8.00-13.00 pH.

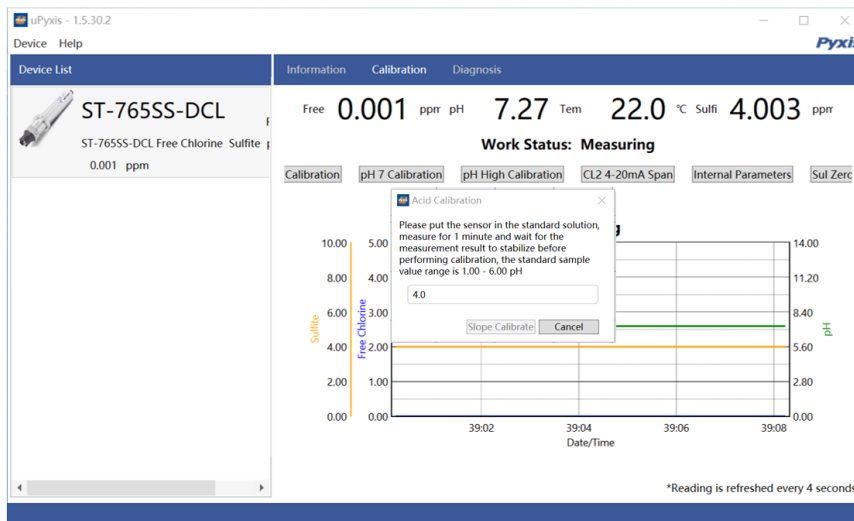

Figure 20 - pH Low Calibration

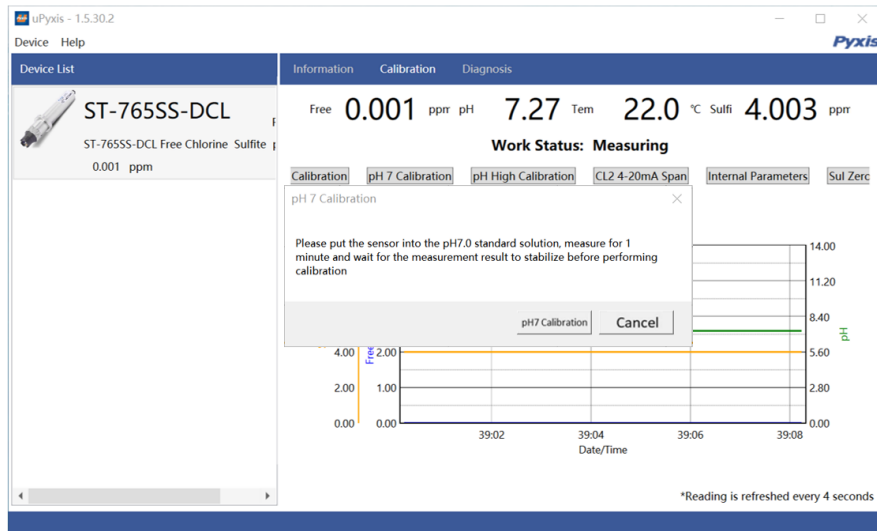

Figure 21 - pH 7 Calibration

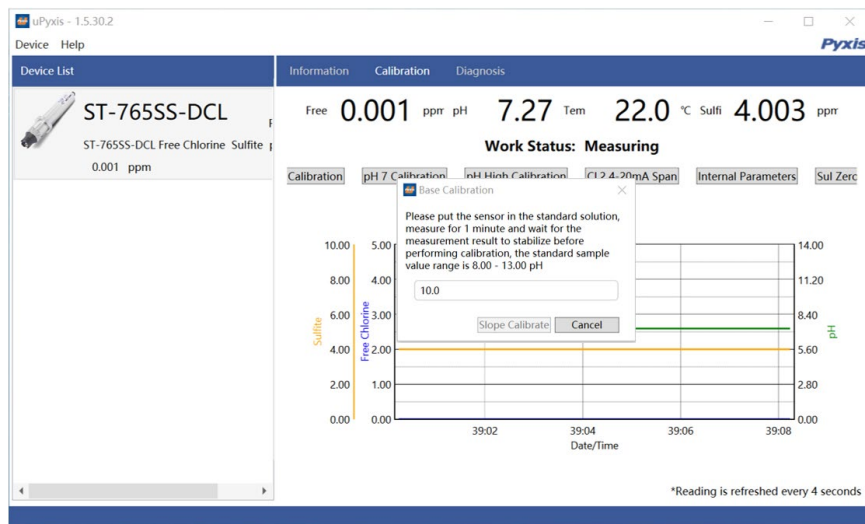

Figure 22 - pH High Calibration

### 6.2.4 4-20mA Span w/uPyxis DESKTOP

The 4–20mA output of the ST-765SS-DCL sensor is scaled as:

- Sulfite:
  - 4 mA = 0 ppm
  - 20 mA = 100 ppm
- Free Chlorine:
  - 4 mA = 0 ppm
  - 20 mA = 5 ppm

Tap **4-20mA SPAN** to change the free chlorine or sulfite value corresponding to the 20mA output to a lower value as seen in *Figure 23,24*. **\*NOTE\*** The 4-20mA Span feature allows users to REDUCE the upper 20mA output scale only. You cannot INCREASE the upper limit of the sensor beyond the range of the sensor.

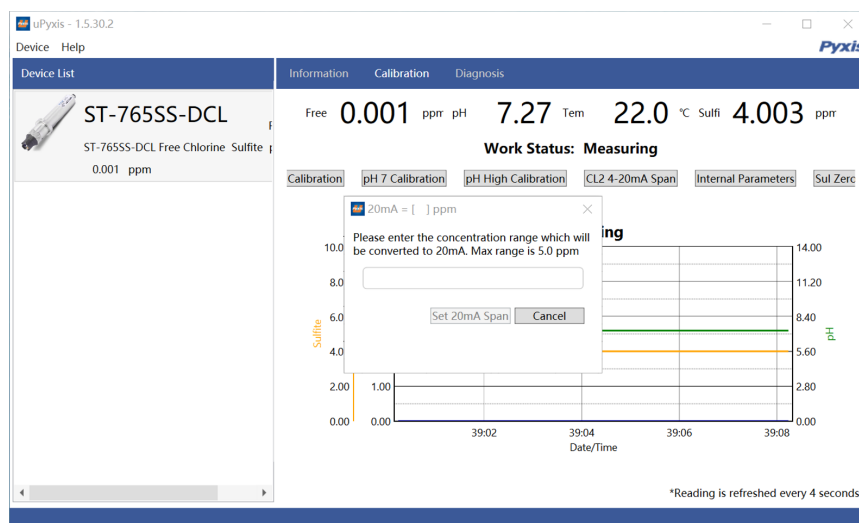

Figure 23 -Set Free Chlorine 4-20mA Span

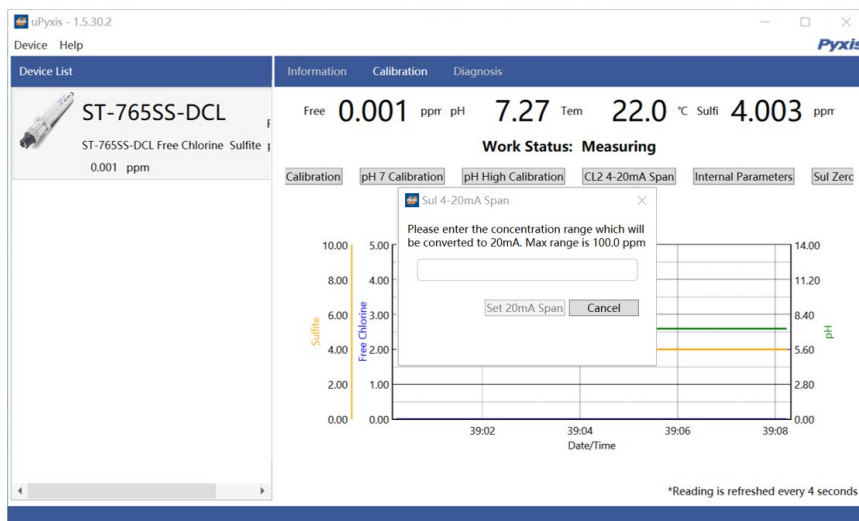

Figure 24 -Set Sulfite 4-20mA Span

### 6.2.5 Diagnosis w/uPyxis DESKTOP

Tap **Diagnosis** in the bottom of the app page to launch the diagnosis page *Figure 25*. In this page, the raw data measured by the sensor is displayed. To help troubleshooting possible issues with the sensor, please save images of these data when the sensor is respectively placed in a clean water (tap water), in a pH standard solution, and in the sample that the sensor is intended for. This data may be exported from the uPyxis APP via email to [service@pyxis-lab.com](mailto:service@pyxis-lab.com) for technical support.

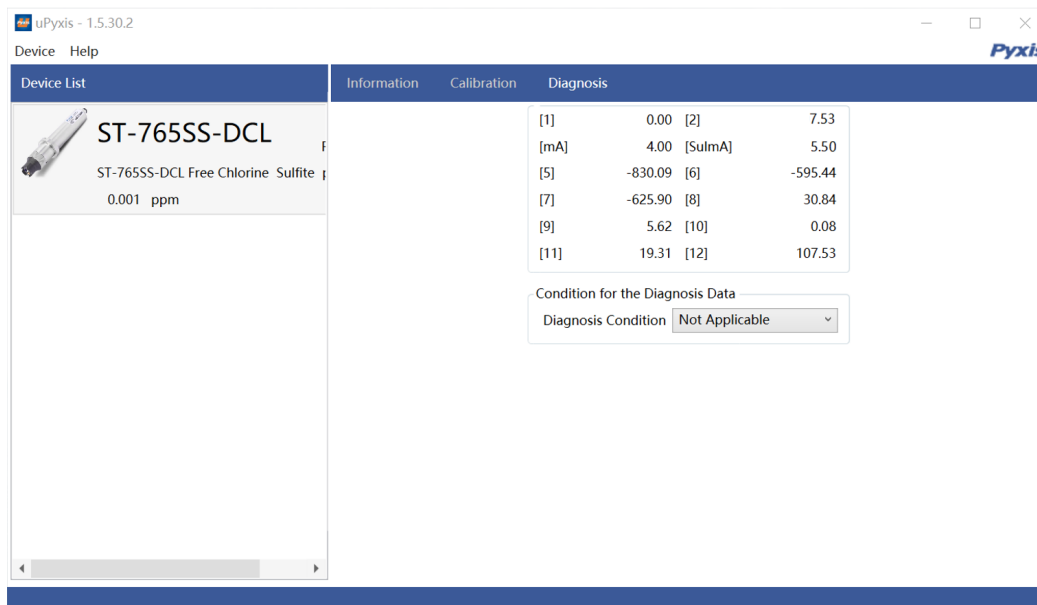

Figure 25 - Diagnostic Interface

### 6.3 Calibration through the Controller

It is recommended that the ST-765SS Series calibration be carried out using the uPyxis app as demonstrated in the sections above. Alternatively, a single point calibration can be carried on the controller by adjusting the mA-to-ppm ratio (Free Chlorine / Sulfite). However, if calibration is to be performed via the controller, it must be cleaned with deionized water prior to calibration, taking care to avoid direct hand contact with the electrodes. Please follow the controller manufacturer's procedures for 4-20mA calibration as with any sensor. With the default settings of the ST-765SS-DCL for free chlorine, the controller should be set to convert 4 mA to 0 ppm and 20 mA to 5.00 ppm. With the default settings of the ST-765SS-DCL for sulfite, the controller should be set to convert 4 mA to 0 ppm and 20 mA to 100.00 ppm.

Calibration of the ST-765SS-DCL sensor should be done with the sensor inline exposed to active flowing sample water. Use a portable or laboratory colorimeter (i.e., SP-800 / SP-910 or similar) to test the active (flowing) water sample in the flow reservoir or tee assembly of sensor installation.

## 7. Modbus RTU

The ST-765SS-DCL Series sensors are configured as a Modbus slave device. In addition to the ppm free chlorine, ppm sulfite, pH and temperature many operational parameters, including warning and error messages, are available via a Modbus RTU connection. Contact Pyxis Lab Customer Service ([service@pyxis-lab.com](mailto:service@pyxis-lab.com)) for more information.

## 8. Sensor Cleaning and Maintenance

Soak the lower half of the sensor in 100 mL inline sensor cleaning solution for 10-15 minutes. Gently rub the sensor electrode head with the provided Q-tips. If the surface is not entirely clean, continue to soak the sensor for an additional time until clean. Rinse the sensor with distilled water.

Pyxis Lab Inline Sensor Cleaning Solution can be purchased at our online Estore/Catalog at <https://www.pyxis-lab.com/product/inline-sensor-cleaning-kit/>



Figure 26 ST-Series Probe Cleaning Kit (P/N SER-01)

### 8.1 Other Common Troubleshooting Issues

If the ST-765SS sensor output signal is not stable and fluctuates significantly, make an additional solution ground connection - connect the black ground wire to a conductor that contacts the sample water electrically such as a brass pipe adjacent to the ST-765SS.



## 9. Replacing pH and Oxidizer Electrode Head

The pH/oxidizer electrode head of ST-765SS Series can be replaced when the original electrode head reaches its working life. The typical working life of the electrode can be as long as 2-years under normal operating conditions. Order a replacement electrode head EH-765 (P/N 53061) from Pyxis and follow instructions as below.

1. Turn off the sensor if it is powered on and make sure there is no water on the sensor.
2. Hold the ST-765SS main body with one hand and use the other hand to twist the stainless-steel locking ring counter-clockwise until the front end of the black electrode is completely unscrewed, as shown in *Figure 27-2*.
3. Pull out the electrode head as shown in *Figure 27-3*.
4. Loosen the electrode plug connector and remove the electrode head, as show in *Figure 27-4*.
5. To assemble the new electrode head, connect the plug, then insert the new electrode head into the main sensor housing and ensure that the two protrusions on the electrode head are aligned with the notches in the sensor main housing.
6. Then twist the stainless-steel lock ring of ST-765SS in a clockwise direction until the threads of the electrode head completely enter the ST-765SS housing as shown in *Figure 27-1*.

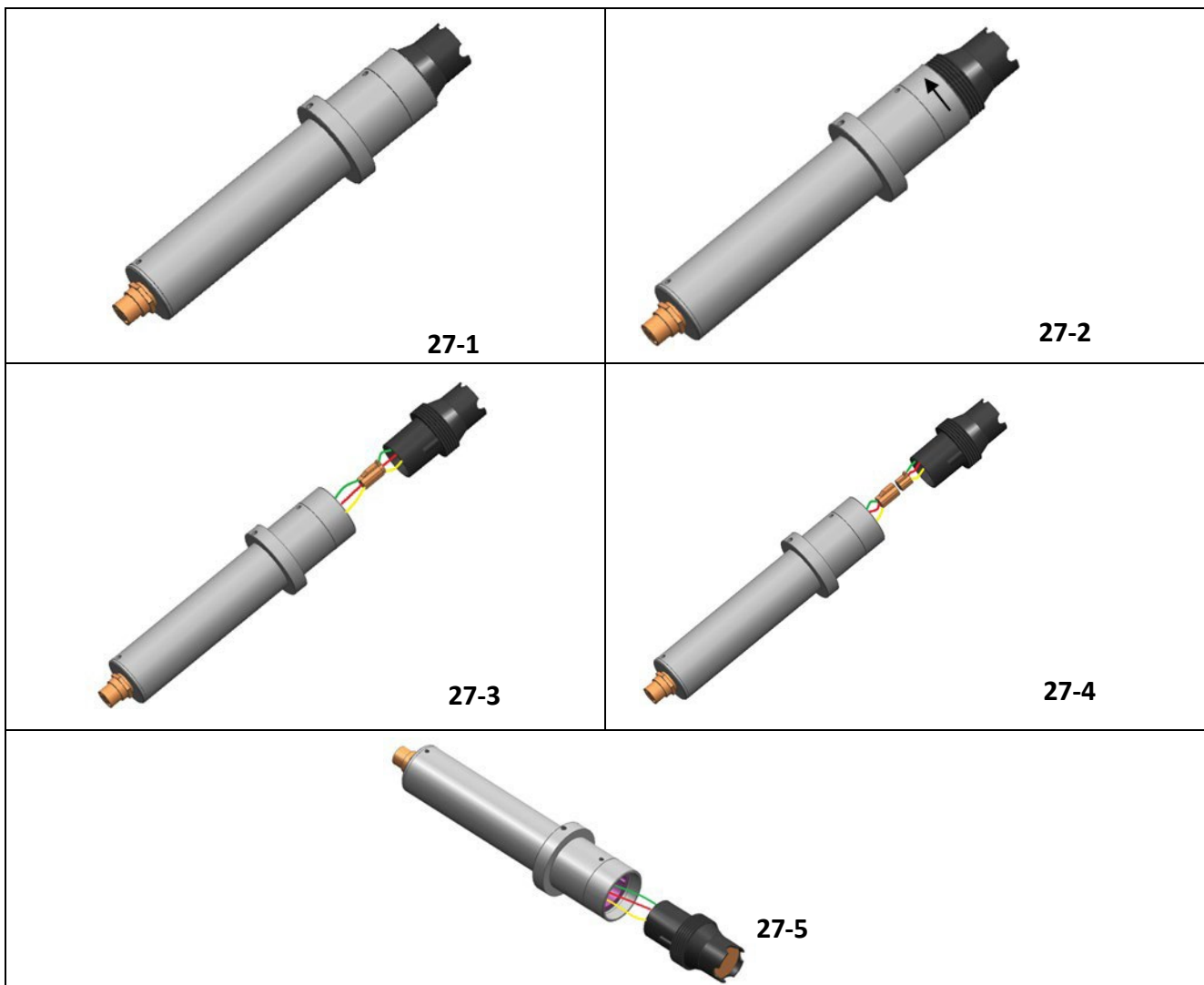

## 10. Contact Us

Pyxis Lab, Inc  
1729 Majestic Dr. Suite 5  
Lafayette, CO 80026 USA  
[www.pyxis-lab.com](http://www.pyxis-lab.com)  
Phone: +1 (866) 203-8397  
Email: [service@pyxis-lab.com](mailto:service@pyxis-lab.com)